



OMTP (7 bar)

FILTRI SUL RITORNO
RETURN FILTERS



LA SERIE DI FILTRI HMM È CONFORME ALLE SEGUENTI NORME ISO:

- ISO 2941 - Oleoidraulica - Elementi filtranti - Verifica della resistenza allo schiacciamento o allo scoppio
- ISO 2942 - Oleoidraulica - Elementi filtranti - Verifica dell'integrità di fabbricazione e determinazione del punto di prima bolla
- ISO 2943 - Oleoidraulica - Elementi filtranti - Verifica della compatibilità dei materiali con i fluidi
- ISO 3723 - Oleoidraulica - Elementi filtranti - Verifica della resistenza alla deformazione assiale
- ISO 3724 - Oleoidraulica - Elementi filtranti - Verifica delle caratteristiche mediante prova di resistenza a fatica in funzione della portata
- ISO 3968 - Oleoidraulica - Filtri - Determinazione della perdita di carico in funzione della portata
- ISO 16889 - Oleoidraulica - Filtri - Metodo Multi-pass: valutazione delle caratteristiche di filtrazione di un elemento filtrante

HMM FILTER SERIES IS SUITABLE TO THE FOLLOWING ISO STANDARDS:

- ISO 2941 - Hydraulic fluid power - Filter elements Verification of collapse / burst resistance
- ISO 2942 - Hydraulic fluid power - Filter elements Verification of fabrication integrity and determination of the first bubble point
- ISO 2943 - Hydraulic fluid power - Filter elements Verification of material compatibility with fluids
- ISO 3723 - Hydraulic fluid power - Filter elements Method for end load test
- ISO 3724 - Hydraulic fluid power - Filter elements Verification of flow fatigue characteristics
- ISO 3968 - Hydraulic fluid power - Filters - Evaluation of pressure drop versus flow characteristics
- ISO 16889 - Hydraulic fluid power filters - Multi-pass method for evaluating filtration performance of a filter element

MATERIALI (elementi filtranti)

Fondelli	Lamiera zincata
Tubo di sostegno	Lamiera zincata
Reti di supporto	Acciaio galvanizzato con rivestimento epossidico

MATERIALS (filter elements)

End caps	Galvanized sheet iron
Support tube	Galvanized sheet iron
Support mesh	Galvanized steel with epox coating

SETTI FILTRANTI / FILTRATION MATERIALS

Elementi filtranti Filter elements	Descrizione Description	Materiale Material	Grado di filtrazione (µm) Filtration (µm)	Rapporto β / β Ratio	
				ISO 16889 βx(c)≥200	ISO 16889 βx(c)≥1000
C10	Carta trattata / Treated paper	Fibre di cellulosa / Cellulose fibre	10	-	-
C25	Carta trattata / Treated paper	Fibre di cellulosa / Cellulose fibre	25	-	-
F03	Fibra inorganica / Inorganic fibre	Fibra di vetro / Glass fibre	3	5	6
F06	Fibra inorganica / Inorganic fibre	Fibra di vetro / Glass fibre	6	6	7
F10	Fibra inorganica / Inorganic fibre	Fibra di vetro / Glass fibre	10	10	13
F25	Fibra inorganica / Inorganic fibre	Fibra di vetro / Glass fibre	25	17	20
R25	Rete a maglia quadra / Square mesh	Aisi 304	25	-	-
R60	Rete a maglia quadra / Square mesh	Aisi 304	60	-	-
R90	Rete a maglia quadra / Square mesh	Aisi 304	90	-	-

SUPERFICI UTILI (cm²) ELEMENTI FILTRANTI / FILTRATION AREA (cm²) FILTER ELEMENTS

OMTPR	20	101	102	103
C10 - C25	870	940	1500	1850
F03 - F06 - F10 - F25	710	670	1020	1670
R25 - R60 - R90	680	670	1020	1590

MATERIALI (corpo)

Testina	Pressofusione di Alluminio
Contenitore	Nylon caricato vetro
Coperchio	Nylon caricato vetro
Guarnizioni	N: Nitrilica (Buna-N)
Valvola di by-pass	Gomma Nitrilica

MATERIALS (housing)

Filter head	Aluminium die-casting
Filter bowl	Glass reinforced nylon
Cover	Glass reinforced nylon
Seals	N: Nitrile (Buna-N)
By-pass valve	Nitrile (Buna-N)

CONDIZIONI DI ESERCIZIO

Pressioni corpo filtro	Pressione massima d'esercizio: 700.000 Pa (7 bar)
Temperatura d'esercizio	Da -20 a +90°C
Pressioni di collasso degli elementi filtranti	500.000 Pa (5 bar)
Pressione taratura valvola di by-pass	150.000 Pa (1.5 bar)
Compatibilità con i liquidi - ISO 2943	Compatibili con oli minerali tipo (HH, HM, HR, HV, HG secondo ISO 6743/4)

WORKING CONDITIONS

Filter pressure	Max working pressure: 700.000 Pa (7 bar)
Working temperature	-20 to +90°C
Collapse pressure (filter element)	500.000 Pa (5 bar)
By-pass valve setting pressure	150.000 Pa (1.5 bar)
Compatibly with hydraulic fluids ISO 2943	Compatible with mineral oils type (HH, HM, HR, HV, HG according to ISO 6743/4)

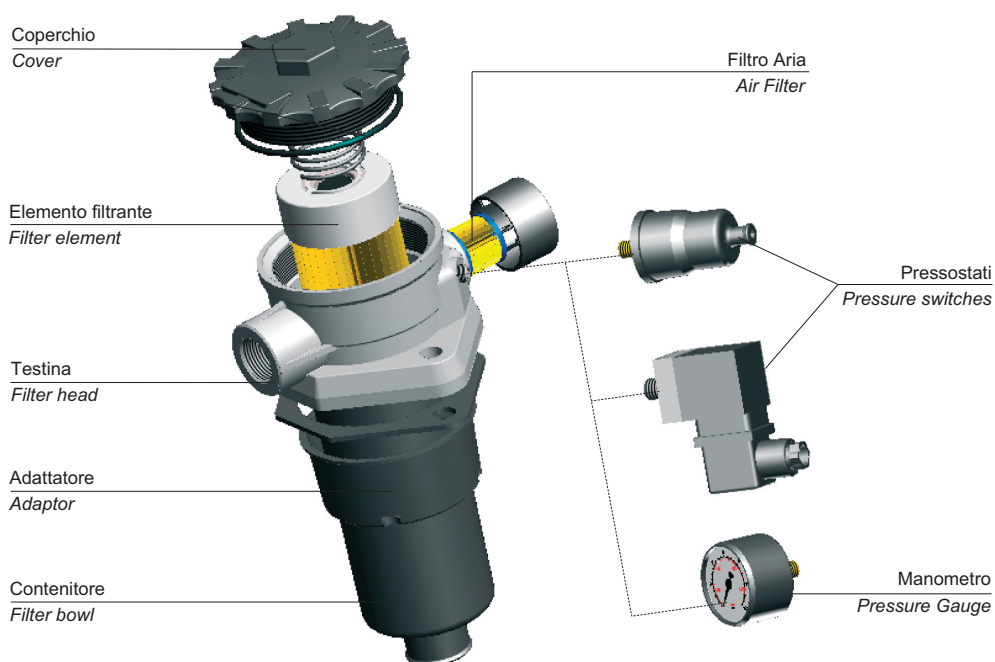

Le portate sono state calcolate per avere una perdita di carico $\Delta p \leq 40.000$ Pa (0.4 bar) con olio minerale avente viscosità cinematica 30 cSt e densità 860 kg/m³. (Vedi note a pag. 77)

Flows have been calculated just in order to obtain a pressure drop $\Delta p \leq 40.000$ Pa (0.4 bar) with mineral oil kinematic viscosity 30 cSt and 860 kg/m³ density. (See remarks on page 77)

ATTACCHI / CONNECTIONS

Tipo / Type	OMTP100
1	3/4" BSP
2	3/4" NPT
3	1" BSP
4	1" NPT
	SAE12

LUNGHEZZE / LENGTHS

Tipo / Type	H1	H2
101	140	110
102	205	175
103	305	275

PORTATE CONSIGLIATE RECOMMENDED FLOWS

OMTP	Elemento filtrante Filter element	Portata (L/min) Flow (L/min)	Peso (kg) Weight (kg)
101	C10	60	0,875
101	C25	60	0,875
101	F06	25	0,875
101	F10	35	0,875
101	F25	60	0,875
102	C10	80	1.0
102	C25	80	1.0
102	F06	35	1.0
102	F10	45	1.0
102	F25	80	1.0
103	C10	100	1.15
103	C25	100	1.15
103	F06	40	1.15
103	F10	60	1.15
103	F25	100	1.15

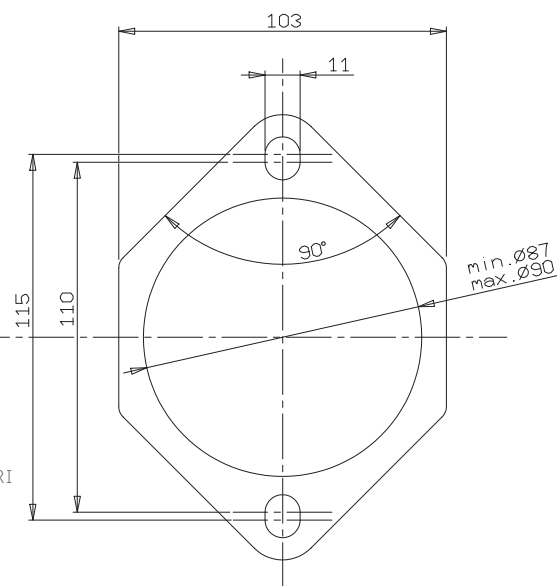
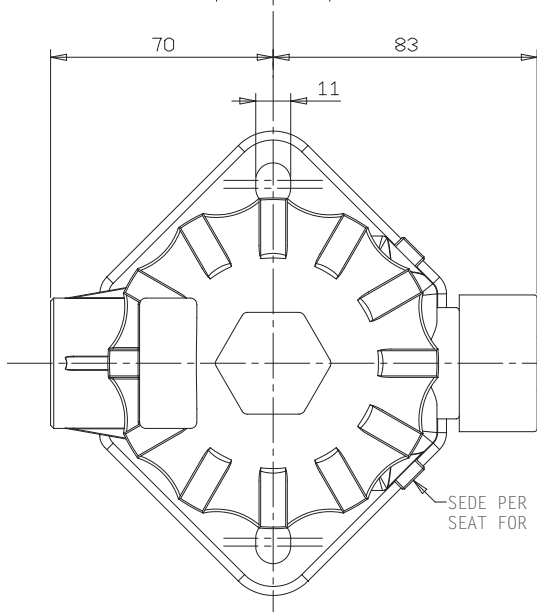
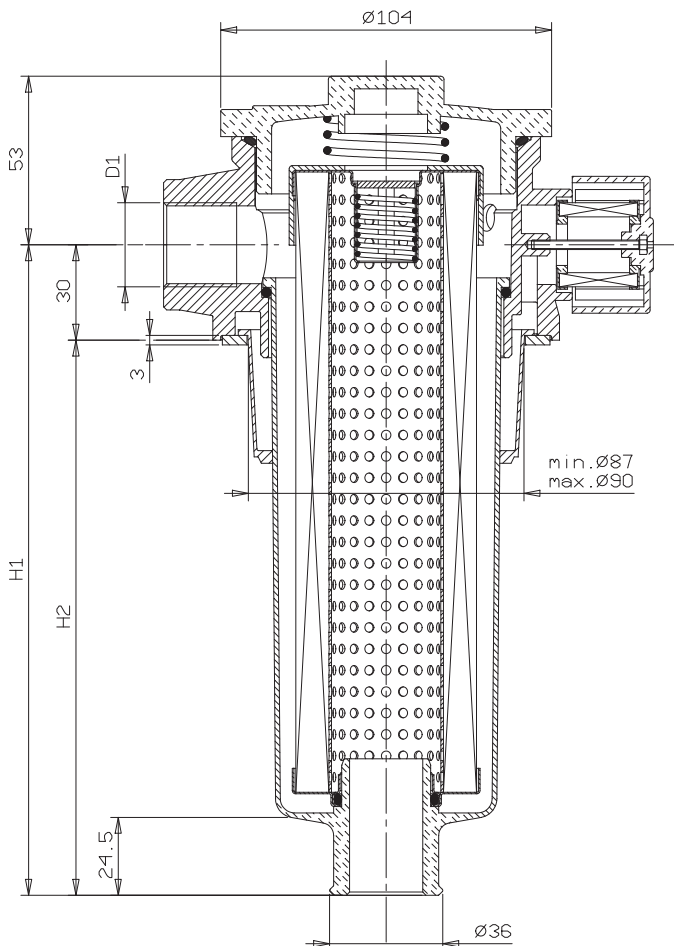

La caduta di pressione completa si ottiene sommando la caduta di pressione del corpo filtro e quella dell'elemento filtrante.

Cadute di pressione nel corpo filtro

Le curve sono valide con olio minerale avente massa volumica di 860 kg/m^3 . La caduta di pressione è proporzionale alla massa volumica.

Cadute di pressione negli elementi filtranti

Le curve sono valide con olio minerale avente viscosità cinematica di 30 cSt. La variazione di caduta di pressione è proporzionale alla viscosità cinematica.

The pressure drop of the complete filter is calculated by adding the pressure drop of the housing to that of the filter element.

Pressure drops in the housing

The graphics refer to the use of mineral oil with a mass density of 860 kg/m^3 . The pressure drop is proportional to the variations of mass density.

Pressure drops in the filter elements

The graphics refer to mineral oil with a kinematic viscosity of 30 cSt. The variation of the pressure drop is proportional to the kinematic viscosity.

OMTP serie/series 20

ΔP CORPI / ΔP HOUSINGS

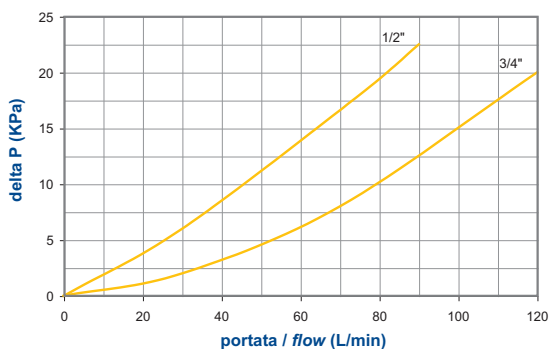

BY-PASS / BY-PASS

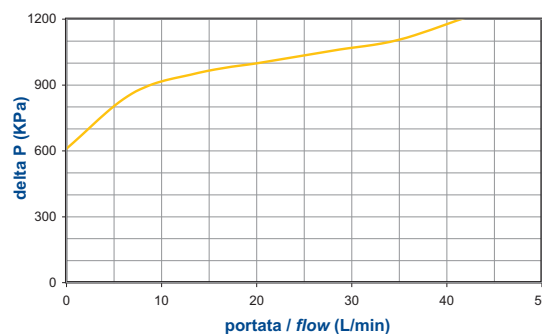

ΔP ELEMENTI

OMTPR20

ΔP ELEMENTS

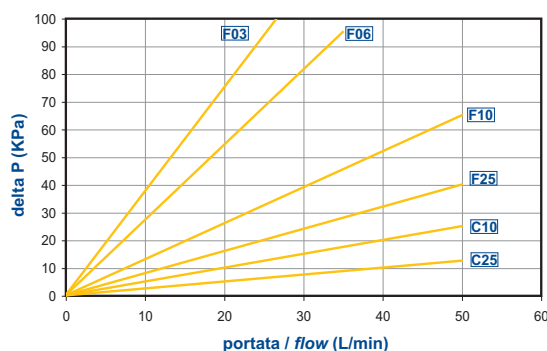

OMTP serie/series 100

ΔP CORPI / ΔP HOUSINGS

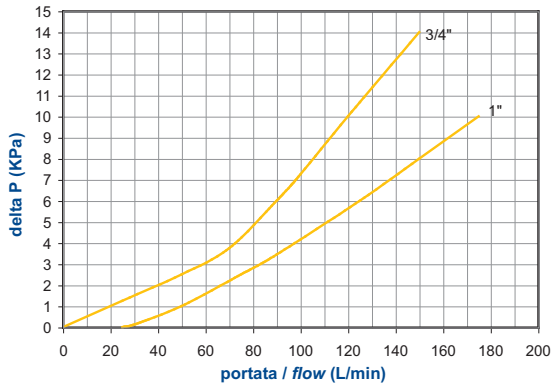

BY-PASS / BY-PASS

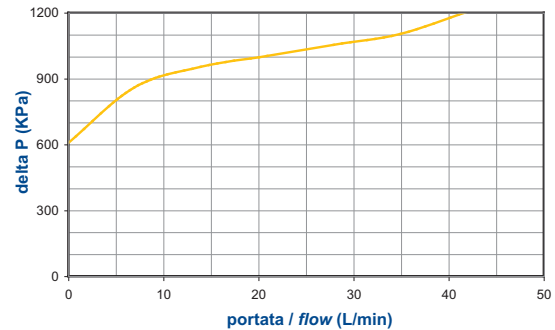

ΔP ELEMENTI

OMPTR101

ΔP ELEMENTS

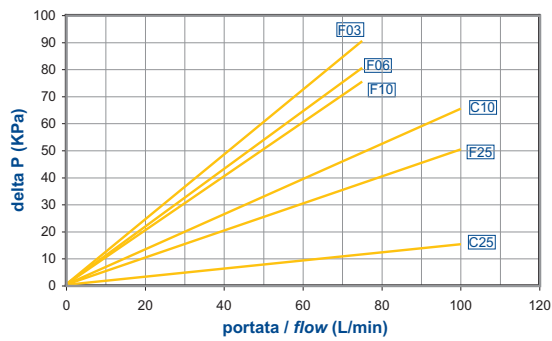

ΔP ELEMENTI

OMPTR102

ΔP ELEMENTS

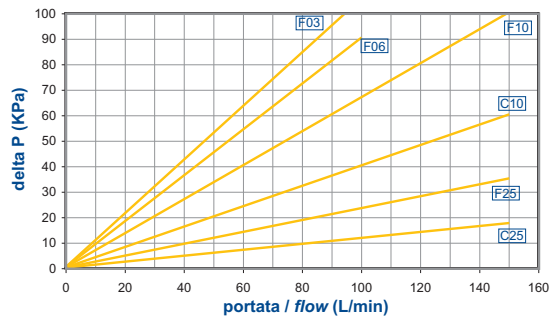

ΔP ELEMENTI

OMPTR103

ΔP ELEMENTS

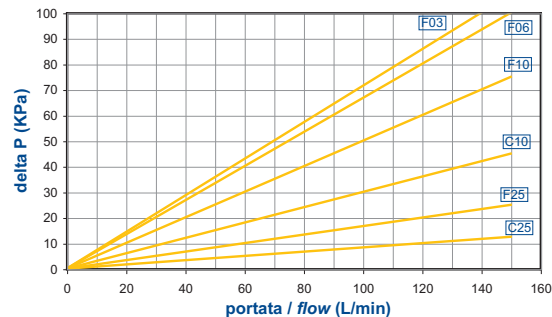

PV1

Manometro
Pressure gauge

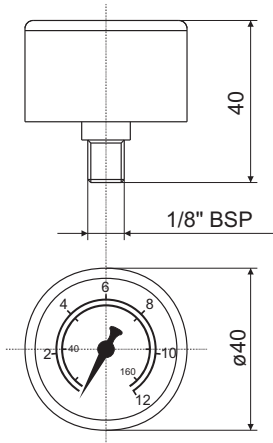

PE1 - PE2

Pressostato
con contatti N.A. o N.C.
Pressure switch
with contacts N.O. or N.C.

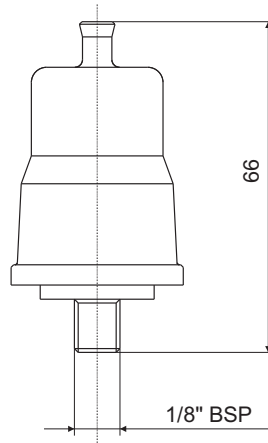

PE3

Pressostato
con contatti in scambio
Pressure switch
with changeover contacts

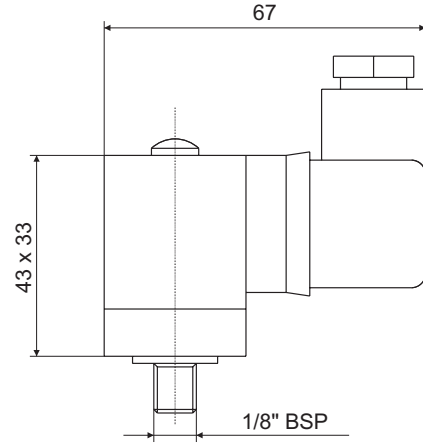

CARATTERISTICHE TECNICHE TECHNICAL DATA

Codice Part number	Descrizione Description	Scala taratura Setting	Contatti elettrici Electrical Contacts	Tipo Type
PV1	visivo visual	0-12 bar	-	Puntuale On the spot
PE1	elettrico electrical	1,3 bar	N.A. / N.O.	
PE2			N.C.	
PE3			Scambio Changeover	

CARATTERISTICHE ELETTRICHE ELECTRICAL DATA

Codice Part number	Tensione max di alimen. (V) Max feeder voltage (V)	Carico resistivo (A) Resistive load (A)	Carico induttivo (A) Inductive load (A)	Protezione (completo) Protection (complete)
PE1	C.A. 48	0,5	0,2	IP 54
PE2	C.A. 48	0,5	0,2	IP 54
PE3	C.A. 250	3	2	IP 65 DIN40050

SIMBOLOGIA / SIMBOLOGY

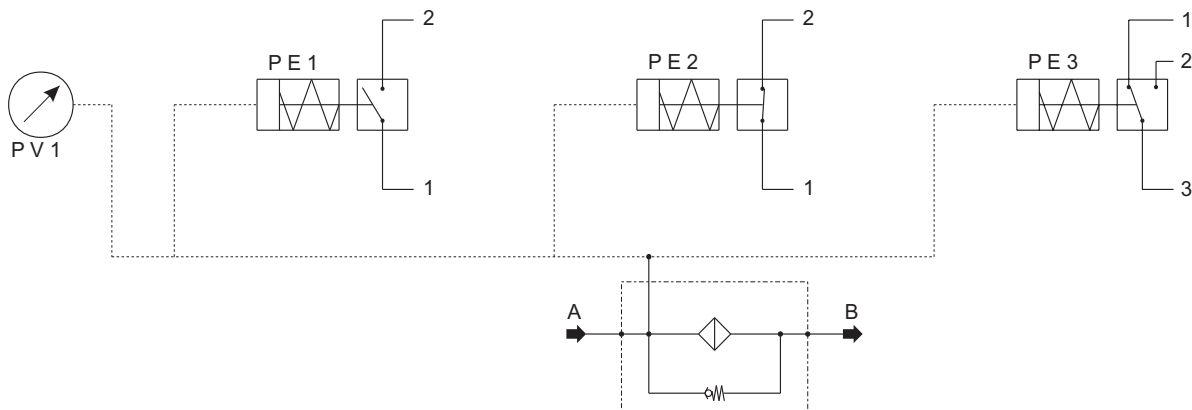

OMTP 101 C10 N 1 - A

Grandezza nominale Nominal Size	Lunghezze Lenght
020	
101	1
102	2
103	3

Elemento filtrante Filtration Element		
C10	10 µm	Carta trattata con resine βx(c)≥2 Resin treated cellulose βx(c)≥2
C25	25 µm	Carta trattata con resine βx(c)≥2 Resin treated cellulose βx(c)≥2
F03	3 µm	Fibre inorganiche βx(c)≥200 Inorganic fibre βx(c)≥200
F06	6 µm	Fibre inorganiche βx(c)≥200 Inorganic fibre βx(c)≥200
F10	10 µm	Fibre inorganiche βx(c)≥200 Inorganic fibre βx(c)≥200
F25	25 µm	Fibre inorganiche βx(c)≥200 Inorganic fibre βx(c)≥200
R25	25 µm	Rete a maglia quadra (Aisi304) Square mesh (Aisi304)
R60	60 µm	Rete a maglia quadra (Aisi304) Square mesh (Aisi304)
R90	90 µm	Rete a maglia quadra (Aisi304) Square mesh (Aisi304)

Guarnizioni Seals	
N	Nitrile / Buna-N

Attacchi Connections		
	OMTP20	OMTP100
	1/2" BSP	3/4" BSP
1	1/2" NPT	3/4" NPT
2	3/4" BSP	1" BSP
3	3/4" NPT	1" NPT
4	SAE8	SAE12

Elemento Filtrante Aria Air Filter Element		
A	10 µm	Carta trattata Resin treated cellulose
B	40 µm	Carta trattata Resin treated cellulose

OMTPR 101 F03 N

Codice per l'ordinazione dell'elemento filtrante di ricambio
How to order the replacement element

* Per l'ordinazione degli indicatori di intasamento, guardare pag. 8
* See page 8 for information how to order clogging indicators